

# ABSOLYTE<sup>®</sup> GP

## VALVE REGULATED, LEAD ACID SINGLE CELL BATTERIES

Providing more batteries to the US Railroad Signal Market during the past decade than all other manufacturers combined!



- 20 year design life
- 104 to 680 AH
- Single cell module for ease of handling
- UL recognized component
- Recyclable to world standards

## MONITOR BATTERY CAPACITY TESTER AND CHARGER WITH ALARMS

- Test to confirm the standby battery is operating to designed capacity
- Battery capacity test result relay and LED indication
- Test data and DC fault alarm log with recall
- Easily programmed microprocessor controlled charger with fail safe circuitry
- DC fault alarm relay and LED indication
- Input/output surge protection



# ABSOLYTE<sup>®</sup> GP

## THE WORLD LEADER IN VRLA BATTERY POWER

- Environmentally friendly positive grid alloy provides reduced hazardous material content<sup>1</sup> and allows global recycling.
- Patented Lead-Calcium-Tin-Silver positive grid alloy provides long life in both float and cycling applications.
- Absorbed glass mat (AGM) separators provide >99% recombination efficiency.
- Low resistance of the glass mat improves high rate discharge performance.
- Cells are housed in protective, individual steel trays with convenient lifting handles for easy transport to remote locations.
- The single cells may be operated in the horizontal (preferred) or vertical position.<sup>2</sup>
- No water additions are required.
- Periodic visual inspections, voltage readings and connection retorquing is all that is required.



1. Compared to Absolyte IIP  
2. 50G single cells only.  
3. When operated per I&O Manual

## APPLICATIONS

The Absolyte GP Single Cell Modules are ideal for numerous applications including

- Crossings
- Signals
- Positive Train Control
- Control Points
- Hot Box Detectors
- AEI Sites
- Track Circuits
- Solar
- Alternative Energy Systems

## ADDED FEATURES & BENEFITS

- Does not require separate battery room
- Can be integrated into other equipment enclosures
- Freezing tolerant
- Deep discharge recovery
- Accepts high rate charge
- Enhanced post access for ease of maintenance and battery health assessment
- Globally recyclable
- Greater use of reprocessed materials compared to prior Absolyte products.

## CELL SPECIFICATIONS

- Separators - Spun glass, microporous matrix.
- Design Life - 20 years in float applications at 25°C (77°F).<sup>3</sup>
- Container and Cover - Polypropylene is standard. flame retardant, UL94 V-0 / 28% L.O.I. is optional.
- Safety Vent - 3-10 psi opening pressure, self-resealing.
- Terminals - Solid copper insert.
- Positive Plate - Patented Lead-Calcium-Tin-Silver grid alloy.
- Negative Plate - Lead-Calcium grid alloy.
- Self Discharge - 0.5 to 1% per week maximum @ 25°C (77°F).
- Float Voltage - 2.23 to 2.27 VPC (2.25 recommended) @ 25°C (77°F).

# ABSOLYTE<sup>®</sup> GP

## Absolyte GP Single Cell Module Weights and Dimensions

CELL TYPE	NOM AH CAP (8 HR)	LENGTH		WIDTH		DEPTH OR HEIGHT		WEIGHT	
		IN	MM	IN	MM	IN	MM	LB	KG
<b>50G</b>									
50G05	104	3.80	97	6.49	165	16.00	406	32	15
50G07	152	3.80	97	6.49	165	16.00	406	39	18
50G11	264	4.55	116	6.49	165	16.00	406	50	23
50G13	312	5.30	135	6.49	165	16.00	406	58	26
50G15	368	6.05	154	6.55	166	16.00	406	66	30
50G19	472	7.67	195	6.67	169	16.00	406	91	41
50G27	680	10.67	271	6.67	169	16.00	406	124	56

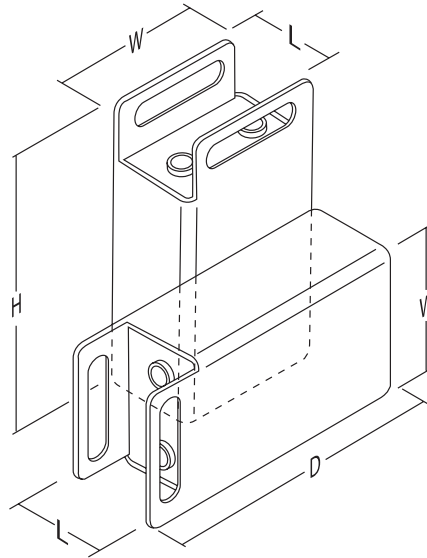

## Absolyte GP Performance Specifications Amperes to 1.75 Final Volts Per Cell @ 25°C (77°F)

CELL TYPE	HOURS													
	100	72	36	24	20	16	12	10	8	6	4	3	2	1
<b>50G</b>														
50G05	1.4	1.9	3.6	5.1	6.0	7.3	9.3	11	13	16	22	27	37	58
50G07	2.1	2.9	5.5	7.7	9.1	11	14	16	19	24	33	41	56	87
50G11	3.6	4.9	9.1	13	15	18	23	27	33	41	56	69	94	146
50G13	4.3	5.9	11	15	18	22	28	33	39	49	67	83	112	175
50G15	5.1	6.9	12	18	21	25	32	38	46	57	78	97	131	204
50G19	6.5	8.9	16	23	27	33	42	49	59	74	101	125	169	262
50G27	9.5	12	23	33	39	47	60	71	85	107	146	181	244	379

Note: Design and/or specifications subject to change without notice. If questions arise, contact your local GNB sales representative for clarification.  
 • Rates shown assume connectors that are properly sized.

# MONITOR Railroad Signal Applications

GNB MODEL	VOLTS NOMINAL	DC AMPS	AC AMPS 120/240VAC	WEIGHT
MM12-15	10-17	15	4.5/2.3	40
MM12-20	10-17	20	6.0/3.0	44
MM 12-30	10-17	30	9.0/4.5	53
MM12-40	10-17	40	12.0/6.0	62
MM24-15	20-34	15	9.0/4.5	40
MM24-20	20-34	20	12.0/6.0	44
MM24-30	20-34	30	18.0/9.0	53
MM24-40	20-34	40	24.0/12.0	62

All units measure 15.75" (w) x 10.5" (d) x 14.75" (h) /400 mm (w) x 264 mm (d) x 375 mm (h)

## ELECTRICAL SPECIFICATIONS

- **AC Input**  
120/240VAC  $\pm$  10%, user selectable, 60 Hz
- **EMI**  
Passed IEC 801.3
- **Input/Output Surge Protection**  
IEEE-C62.41, Category C1  
Withstands Positive & Negative 8x20 $\mu$ s surges on AC & DC lines up to 6000V/3000A
- **Isolation Rating**  
3000V RMS Input to Output  
1500V RMS Input to Chassis
- **DC Output**  
Float Voltage, Equalize Voltage and Minimum Discharge Voltage are adjustable over the following ranges:  
12 volt models: 10 to 17 volts  
(5 to 7 cells Lead-Acid/7 to 11 cells Nickel-Cadmium)  
24 volt models: 20 to 34 volts  
(11 to 14 cells Lead-Acid/17 to 22 cells Nickel-Cadmium)
- **Output Ripple:**  
**With Battery**  
100% output: 0.11 Vrms (typical)  
50% output: 0.057 Vrms (typical)  
**Without Battery**  
100% output: 1.41 Vrms (typical)  
50% output: 0.857 Vrms (typical)
- **Temperature Compensation**  
Chargers are temperature compensated to safely float batteries. Controller software is able to sense a missing or shorted temperature probe, and in such cases the charger will revert to the programmed output without compensation.
- **DC Fault Alarm Relay and LED**  
The microprocessor continuously monitors the DC output. If a qualified "DC Fault" condition is detected, the Fault Alarm Relay and LED are activated.
- **Test Result**  
The Test Result Relay and LED will activate as a result of a low battery capacity condition.
- **Overshoot/Inrush Current**  
No overshoot at turn on, turn off.  
Very low inrush current at power up.
- **Operating Temperature Range**  
Operation from -40°C to +71 °C at a relative humidity up to 100% noncondensing.
- **Storage Temperature Range**  
-40°C to + 85°C
- **Shock and Vibration**  
Charger conforms to ANSI/NEMA PE 7-1 sec. 7.5 and 7.6 without physical damage or degradation to performance.
- **Mounting**  
Mounting brackets are included for wall mount, shelf mount, and 19 in. rack mount.
- **Patented Design**  
Patent number 5,621,298



# ABSOLYTE<sup>®</sup> GP

## FOR USE WITH ALL RAILROAD SIGNAL BATTERY APPLICATIONS

The ultimate smart charger for railroad applications. The fully programmable microprocessor control will set a new standard for ease of use and technological superiority.



## BATTERY TESTER AND CHARGER COMBINATION:

A valid battery capacity test can be performed with the loads connected and the system operating. Pressing one button activates the test and measures the stored results. The maintainer does not have to remain on site. The test process is automatically completed with a timed equalize charge and return to float. The maintainer can recall and record test results at any future time. The MONITOR will provide a local and remote indication of the test results!

**AN EASY, ACCURATE METHOD TO TEST BATTERY AMPERE-HOUR CAPACITY.**

---

# GNB Industrial Power – The Industry Leader.



GNB Industrial Power, a division of Exide Technologies, is a global leader in network power applications including communication/data networks, UPS systems for computers and control systems, electrical power generation and distribution systems, as well as a wide range of other industrial standby power applications. With a strong manufacturing base in both North America and Europe and a truly global reach (operations in more than 80 countries) in sales and service, GNB Industrial Power is best positioned to satisfy your back up power needs locally as well as all over the world.

Based on over 100 years of technological innovation the Network Power group leads the industry with the most recognized global brands such as ABSOLYTE®, GNB® FLOODED CLASSIC®, MARATHON®, ONYX™, RELAY GEL®, SONNENSCHNEIN®, and SPRINTER®. They have come to symbolize quality, reliability, performance and excellence in all the markets served.

GNB Industrial Power takes pride in its commitment to a better environment. Its Total Battery Management program, an integrated approach to manufacturing, distributing and recycling of lead acid batteries, has been developed to ensure a safe and responsible life cycle for all of its products.

Contact Us: (866) 324-4410